

# Directional valve 2-way/2-position

$Q_{\max} = 10 \text{ gpm}$ ,  $p_{\max} = 5000 \text{ psi}$

pilot operated, poppet type, switching solenoid with emergency override

Type series: WR22O\_A5-...



- Screw-in cartridge valve
- For cavity AL
- All external parts with zinc-nickel coating according to DIN EN ISO 19598
- Installation in threaded port body type GALA
- The slip-on coil can be rotated, and it can be replaced without opening the hydraulic envelope
- High pressure wet-armature solenoids
- Various plug-connector systems and voltages are available
- Seat tight shut-off
- Compact construction
- High flow rates
- Low head loss
- Reliable switching, even after long dwell times
- With manual override

## Description

The 2-way/2-position solenoid-operated directional seat valves, series WR22\_A..., are size 5, two stage, pressure balanced screw-in valves with a 3/4-16 UNF-2A mounting thread. The main and pilot stages are both designed on the poppet/seat principle, and the 1 to 2 flow path is therefore virtually leak-free. The straightforward design delivers a good price/performance ratio and outstanding head loss/ flow ratings. All external parts of the screw-in valves are zinc-nickel plated, and are thus suitable for use in the harshest

operating environments. The slip-on coils can be replaced without opening the hydraulic envelope and can be positioned at any angle through 360°. These valves are primarily used as pilot valves in certain mobile and industrial applications where leak-tight shut-off functions are crucially important. Examples are where loads, tensions, or clamping forces must be held without leakage. For self-assembly, please refer to the section related data sheets.

## Symbol

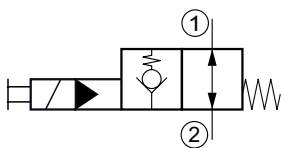

## Technical Data

General Characteristics	Description, value, unit
Function group	Directional valve
Function	2-way/2-position
Design	Screw-in cartridge valve
Controls	switching solenoid with emergency override
Characteristic	pilot operated, poppet type
Construction size	nominal size 5
Thread size	3/4-16 UNF-2A
Mounting attitude	unrestricted
Weight	0.88 lb
Cavity acc. factory standard	For cavity AL
Tightening torque steel	35 ft·lb
Tightening torque aluminium	34 ft·lb
Tightening torque tolerance	± 10 %
Minimum ambient temperature	- 13 °F
Maximum ambient temperature	+ 122 °F
Surface protection	All external parts with zinc-nickel coating according to DIN EN ISO 19598
Available seal types	several seal types available, see ordering code
Seal kit order number	NBR: DS-246-N / FKM: DS-246-V

Hydraulic Characteristics	Description, value, unit
Maximum operating pressure	5000 psi
Maximum flow rate	10 gpm
Flow direction	see symbol
Hydraulic fluid	HL and HLP mineral oil according to DIN 51 524; other fluids on request!
Minimum fluid temperature	- 13 °F
Maximum fluid temperature	+ 176 °F
Viscosity range	10 ... 500 mm <sup>2</sup> /s (cSt)
Recommended viscosity range	15 ... 250 mm <sup>2</sup> /s (cSt)
Minimum fluid cleanliness (cleanliness class according to ISO 4406:1999)	class 20/18/15

**NOTE!**

The switching safety of the valve is achieved by the volume flow and pressure drop ( $\Delta p$ ).

Electric Characteristics	Description, value, unit
Actuator type	solenoid coil
Solenoid coils type	D36
Supply voltage DC	12/24 V DC
Supply voltage AC	115/230 V AC (50 ... 60 Hz)
Supply voltage tolerance	± 10 %
Maximum permissible power consumption	Version "E": V DC = 17 W / V AC = 17 W Version "N": V DC = 27 W / V AC = 25 W
Switching time	Version "E": 35...105 ms (energized) / 20...70 ms (de-energized) Version "N": 25...135 ms (energized) / 20...40 ms (de-energized)
Relative duty cycle	100 %
Electrical connection coil	several connection types available, see ordering code
Protection class solenoid coil to ISO 20 653 / EN 60 529	several classes of protection available, see ordering code (with appropriate mating connector and proper fitting and sealing)



**NOTE!**

The switching time can be strongly dependent on flow rate, pressure, oil viscosity and the dwell time under pressure. In practice, the switching time may therefore deviate from the specified value range.

**Performance graphs**

measured with oil viscosity 33.0 mm<sup>2</sup>/s (cSt), coil at steady-state temperature and 10 % undervoltage

p = f (Q) Performance limit

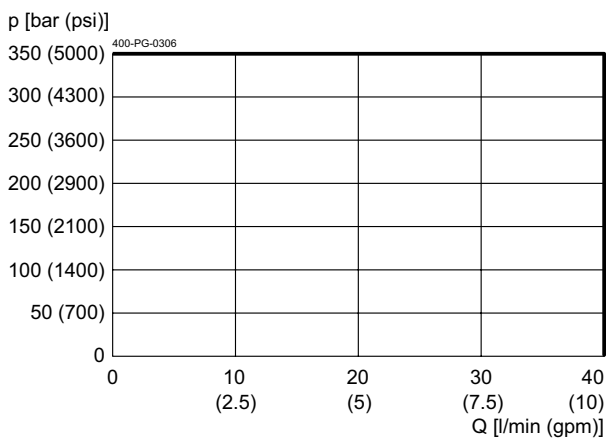

Δp = f (Q) Pressure drop-flow rate characteristic

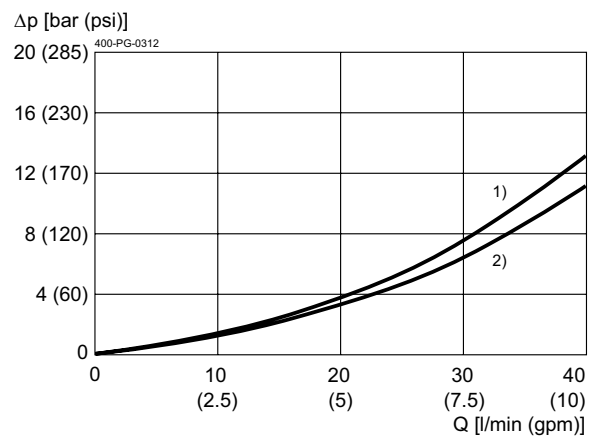

Version "E" - 17 W / Version "N" - 27/25 W

1) 2 → 1, solenoid de-energized

2) 1 → 2, solenoid de-energized

Dimensions and sectional view

**Beispiel für die Masseinheit:**  
**Example for the dimensional units:**  
0.79 = 0.79 mm millimeter  
(.031) = 0.031" inch

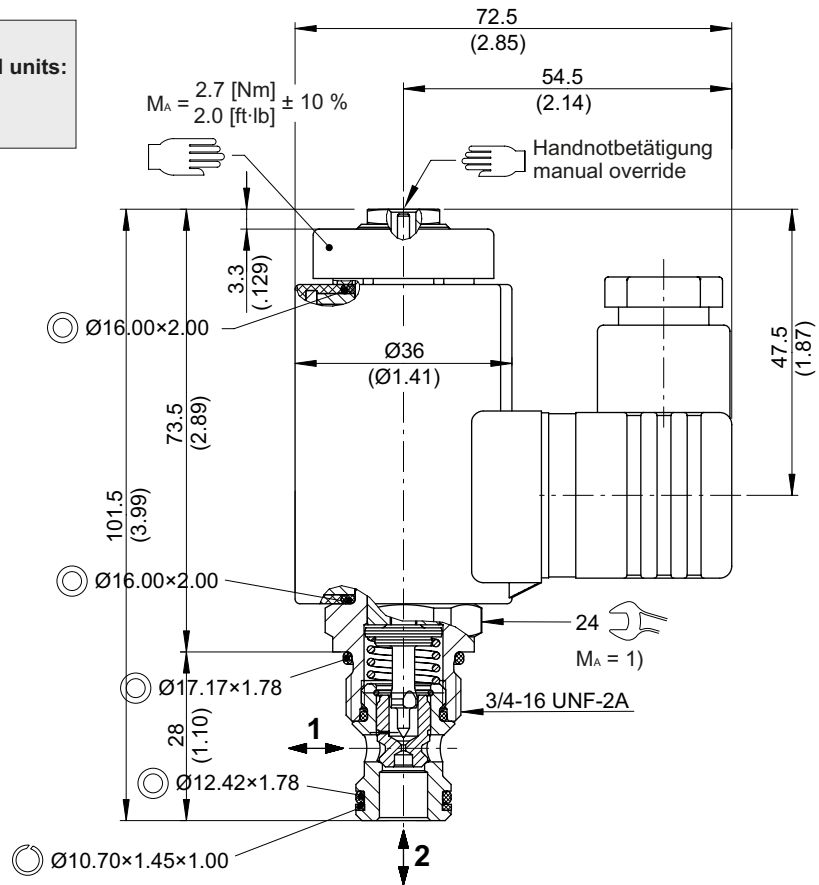

Installation information



**NOTE!**

1) When fitting the screw-in cartridge valve, use the specified tightening torque. The value can be found in the chapter "technical data".



**NOTE!**

The seals are not available individually. The seal kit order number can be found in the chapter "Technical data".



**ATTENTION!**

Only qualified personnel with mechanical skills may carry out any maintenance work. Generally, the only work that should ever be undertaken is to check, and possibly replace, the seals. When changing seals, oil or grease the new seals thoroughly before fitting them.

Ordering code

Ex. 

W	R	22O	E	A	5	_	-	5		24	D	_
---	---	-----	---	---	---	---	---	---	--	----	---	---

- W = directional valve
- R = check valve function, pilot operated
- 22O = 2-way/2-position, normally open
- E = electrically operated, V DC = 17 W / V AC = 17 W (standard)
- N = electrically operated, V DC = 27 W / V AC = 25 W
- A = thread size 3/4-16 UNF-2A for cavity AL
- 5 = nominal size 5
- (blank) = NBR (nitril-butadien-rubber / BUNA) seals (standard)
- V = FKM (fluorocarbon rubber / VITON) seals (special seals - please consult BUCHER)
- 1 ... 9 = technical design no. (omit when ordering)
- ... = voltage e.g. 24 (24 V)
- D = current DC
- A = current AC
- (blank) = DIN EN 175301-803 connection, 3-pole 2 P+E with mating plug (IP 65) (standard)
- M100 = DIN EN 175301-803 connection, 3-pole 2 P+E
- C = Kostal plug connection (IP 65)
- JT = Junior Timer radial plug connection (with protection diode, IP 65)
- IT = Junior Timer axial plug connection (with protection diode, IP 65)
- D = Deutsch plug connection 45° DT04-2P (IP 67/69K)
- DT = Deutsch plug connection 45° DT04-2P (with protection diode, IP 67/69K)
- S = AMP Superseal 1.5 (IP 67) / Metri-Pack 150 (IP 65) plug connection
- F = flying leads (500 mm)

} mating plug not supplied

Related data sheets

Reference	Description
400-P-040011	Forming tools
400-P-040171	Cavity AL
400-P-720101	Threaded port body GALA
400-P-120110	Solenoid coil D36